

Parts List

Index	Description	Qty.
1	Frame Bracket, Left	1
2	Frame Bracket, Right	1

Bag 873

3	Screw Hex, Chrome M10-1.25 x 75	2
4	Screw Hex, Chrome M8-1.25 x 75	2
5	Spacer, Chrome 0.80 Length	2

Tools Needed

- Hex Key Wrench 6mm
- Hex Key Wrench 8mm

INSTALLATION

- Loosen all six fender rail screws.
- Remove the front and rear screws from one side.
- Position frame bracket, start front screw, M10-1.25 x 75.
- Position spacer (**see note below**) into pocket at rear hole, start M8-1.25 x 75 screw through mount bracket and spacer, then into fender.
- Repeat on other side.
- Tighten to: M8= 22 ft-lbs, M10= 29 ft-lbs

NOTE: Do not use the rear spacers when mounting the Cruiseline Saddlebag Frame together with a Paladin QuickSet Rack and Back Rest.

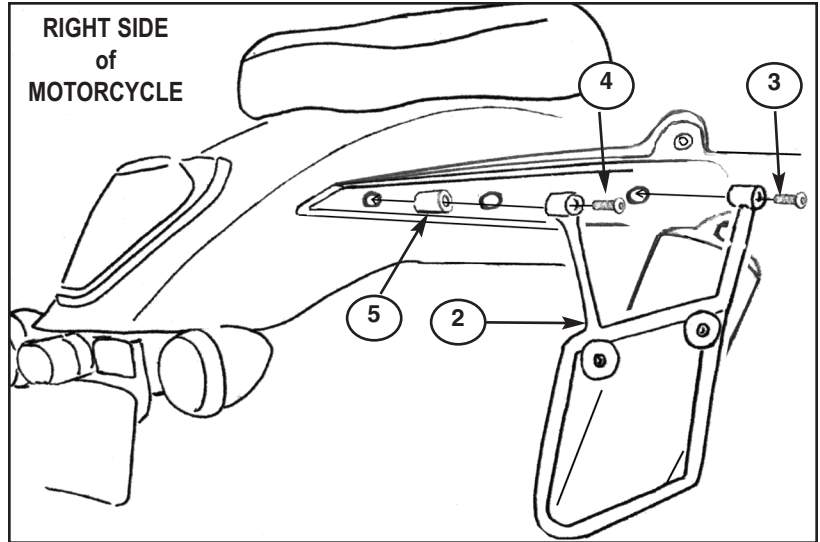

INSTALLATION OF SADDLE BAG TO FRAME

Rest the stainless steel clips attached to the outside of the bag to the lower section of the frame. Engage the quarter turn fastener to the frame. Push in and turn clockwise one quarter turn. There will be a slight spring pressure against the fastener, turn until it stops. Grab the side of the bag, wiggle it. The bag should be firmly set. If fastener is loose, repeat installation of bag to frame.



Turn Fastener clockwise one quarter turn.

Saddlebag Care: Wash with a mild soap or detergent and warm water. Use a soft cloth. To remove tar use naphtha or turpentine.

Painting: Lightly sand the surface with 600 grit sandpaper and spray lacquer, urethane or other paint.

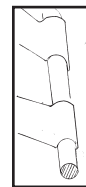

Rest clip on lower section of frame

Replacement Parts: Contact National Cycle, Inc

! WARNING

Not to exceed 11 lbs (5kg) weight per bag. Do not exceed 80 mph (129 kph) when saddlebags are mounted.

On some motorcycles, additional accessories can reduce a motorcycle's stability and safe operating speed. Never ride a motorcycle that exhibits any unsafe handling characteristics. Remove all accessories and cargo at once. Have your dealer diagnose and solve the problem before remounting your accessories.