

Thank you for purchasing a National Cycle product. Read these instructions carefully and thoroughly before beginning work. Dealers, if installing this windshield for a customer, please give them this manual upon completion. It contains information needed to properly maintain and use this product.

N30006 PARTS LIST

ITEM	PART NO.	DESCRIPTION	QUANTITY
A	20-290776-000	Full Size Windshield, Quantum® Hardcoated, 4.0mm Polycarbonate, Clear	1
BAG#1323			
B	44-449372-000	Clamp, Wraparound, 2.00, UTV	6
C	44-449380-000	Grommet Retaining Pin for Wraparound Clamp	6
D	49-490355-000	Flat Nylon Washer, .39 x .68 x .125, Black	6
E	55-563131-000	Machine Screw, Panhead, Philips, #12 x 1.25, Type B, Self Tapping, Stainless	6
F	75-764022-000	Adhesive Clamp Spacer, Poron, .125 x .750 x 6.00	4
G	75-764023-000	Adhesive Clamp Spacer, Neoprene, .093 x .875 x .750	2
H	75-764024-000	Adhesive Clamp Spacer, Neoprene, .093 x .875 x 2.125	2

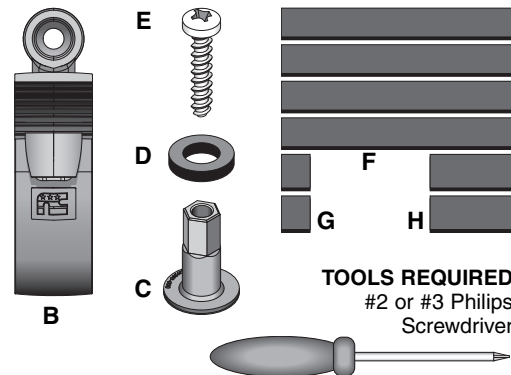

PREPARATION

Carefully unpack your new windshield, sort the parts, and make sure you have everything required to complete the assembly.



Figure 1

INSTALLATION

Figure 1

Unbuckle roof and prop it up from the top rail with a block of wood or similar sturdy device.

Figure 2

Remove the adhesive backing from the four 6.00" Poron Clamp Spacers (F) and adhere them to the inside of four of the Wraparound Clamps (B) as shown. *These will be the bottom Clamps for the vehicle's side roll bars and the top Clamps for the top of the roll bar.*

Figure 3

Place the four Wraparound Clamps from **Figure 2** at the top of the roll bar and at the bottom of the side roll bars at the locations shown.

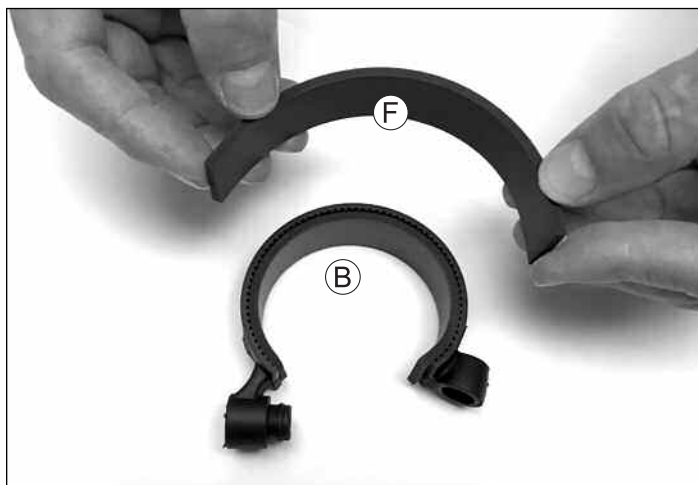

Figure 2



Figure 3

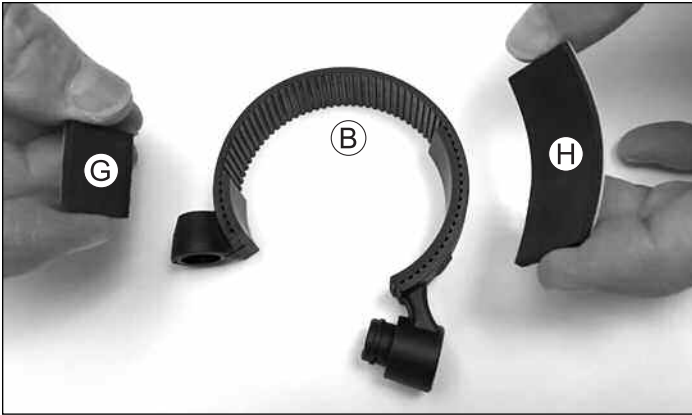

Figure 4

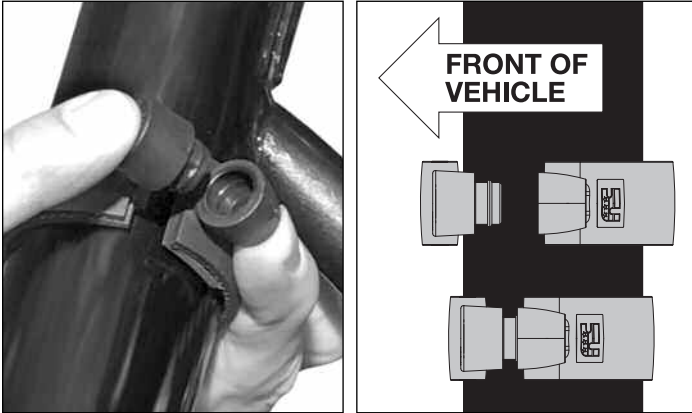

Figure 5

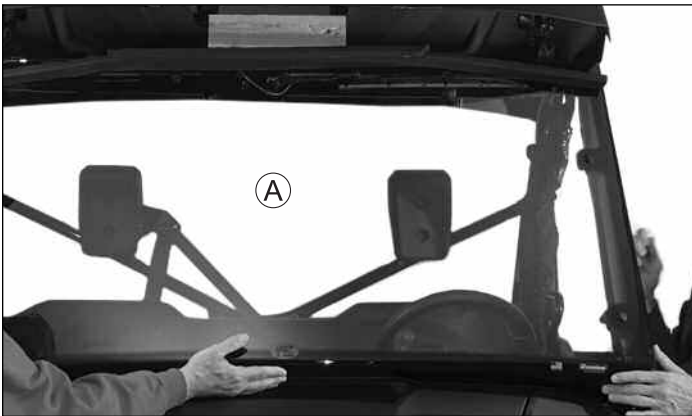

Figure 7

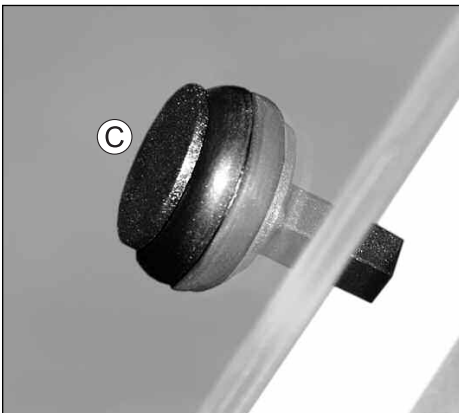

Figure 8

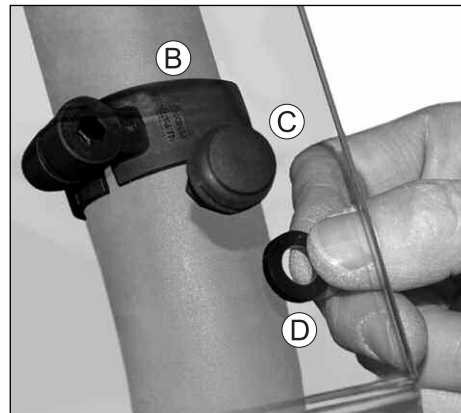

Figure 9



Figure 10



Figure 5

INSTALLATION; CONT'D.

Figure 4

Remove the adhesive backing from the two .75" Neoprene Clamp Spacers (G) and the two 2.125" Neoprene Clamp Spacers (H) and install them on the remaining two Wraparound Clamps (B) as shown. *These will be the top Clamps for the vehicle's side roll bars.*

Figure 5

Place the two Wraparound Clamps from **Figure 4** at the upper sides of the roll bar at the locations shown. Squeeze the ends of the Wraparound Clamps together, but leave them loose enough for final positioning with the Windshield.

Figure 6

On the passenger side, the upper Wraparound Clamp is placed just below the top section of the passenger grab rail.

Figure 7

Place Windshield (A) onto vehicles's front roll bar.

Figure 8

Insert six Grommet Retaining Pins (C) through the front of the Windshield and its grommets.

Figure 9

On each Grommet Retaining Pin, place a Flat Nylon Washer (D) on the inside of the Windshield.

Figure 10

Reposition the Wraparound Clamps (B) so that their forward receptacles align with and capture the Grommet Retaining Pins. Squeeze the assembled components together.

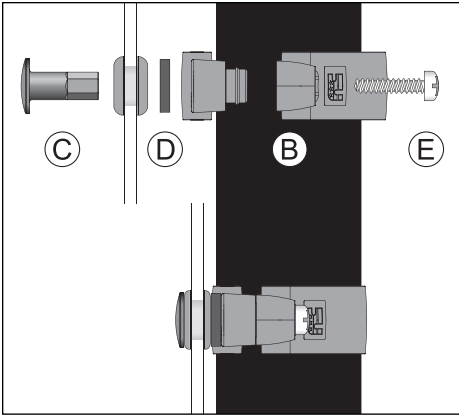

Figure 11

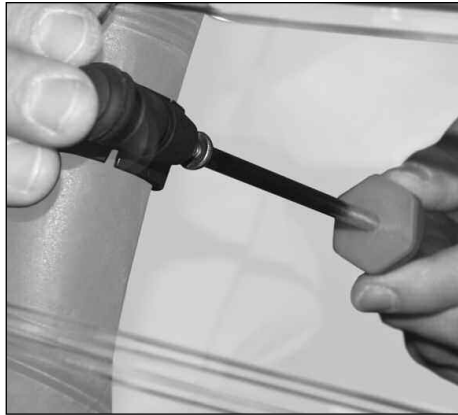

Figure 12

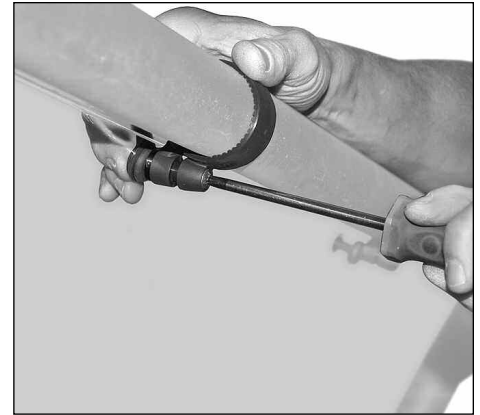

Figure 13



Figure 14



Figure 15

INSTALLATION; CONT'D.

Figure 11

Double-check that you have the placement and orientation of the components assembled correctly.

Figures 12-13

Through the back of each Wraparound Clamp (B) and from inside the cab, insert a Machine Screw (E) with a Phillips screwdriver until it captures the threaded portion of the Grommet Retaining Pin (C). Tighten each screw but don't torque down on them yet.

Do a final check on the positioning of the Windshield, making sure that it's evenly centered and horizontally level.

Once you are satisfied, tighten each of the six Machine Screws firmly and securely.

Figure 14

Remove the improvised support for the vehicle's roof. Reposition the two roof clamps into the top roll bar and clamp them shut.

Figure 15

Your new Quantum® Hardcoated Polycarbonate Windshield is now fully assembled.

Test ride for function and performance, and enjoy your new National Cycle UTV Windshield!



Ask for Shield Wash™ and RainZip® at your local dealer or visit www.nationalcycle.com.

CLEANING AND MAINTENANCE

To clean your windshield, wash with a clean soft cloth and plenty of warm water and, if necessary, a non-abrasive soap such as dishwashing liquid. Flannel or soft cham-
ois make good cleaning cloths. **Paint, glue residue or grease removal:** Moisten cot-
ton wad with naphtha or turpentine followed by a wash as above.

National Cycle **Shield Wash™** (N1401-01) makes a good daily cleaner and comes with a handy travel-size bottle. Shield Wash is safe for all windshields and helmet visors.

Do not clean polycarbonate in hot sun or high temperatures. Do not clean the screen with household glass cleaners.

Do not allow brake fluid, alcohol, or strong solvents to contact the windshield.

RAIN REPELLENT

Do not use rain protective products made for glass. We recommend National Cycle's **RainZip®** (N1410-01) to keep your windshield clear in rainy weather.



National Cycle 3-Year Limited Warranty

Register Your Windshield Online at www.nationalcycle.com

National Cycle hereby warrants to the original registered owner of a National Cycle polycarbonate windshield for a period of three years from the date of purchase against breakage. This limited warranty is expressly limited to the replacement of the polycarbonate windscreen. This limited warranty does not include scratches, coating failure, cosmetic wear and tear, replacement of hardware, or any consequential damages or expenses including labor cost of installation, removal and/or replacement, inconvenience, inbound freight expenses or damage to any other component of the vehicle or any other accessories. Certain chemicals, generally known as acidic hydrocarbons, are known to cause polycarbonate damage and will not be covered under this limited warranty. Please refer to the cleaning instructions supplied with all National Cycle windshields. Visit www.nationalcycle.com for further details or call or write National Cycle Inc.

⚠ WARNING

Never operate your vehicle with loose accessory mounting hardware. Check the hardware for tightness regularly.

UTVs are built with enough frame rigidity to withstand the moderate loads imposed on them by the foreseeable addition of an accessory(ies). If an accessory(ies) adversely affects your vehicle's stability, immediately remove the accessory(ies). Do not operate a vehicle that exhibits unsafe handling traits.

Have experienced service personnel correct any problem before driving with the accessory(ies) installed. For further questions concerning handling problems associated with an accessory(ies), contact your dealer, UTV manufacturer, or accessory manufacturer.

Sunlight reflected off the inside curvature of the windshield can, at certain times of the day, cause extreme heat buildup on the vehicle's instruments and possibly even melt them. Exercise care in parking to avoid this. Park your vehicle facing the sun, or place an opaque object over the instruments and dash panel.