



Thank you for purchasing a National Cycle product. Read these instructions carefully and thoroughly before beginning work. Dealers, if installing this product for a customer, please give them this manual upon completion. It contains information needed to properly maintain and use this product.

Description:	Luggage Rack	Model:	2018-Later Yamaha® MT-07
Part Number:	P9305	Installation Time:	45-60 min.

### P9305 PARTS LIST

ITEM	PART NO.	DESCRIPTION	QUANTITY
A	37-374662-300	Luggage Rack, Powdercoated, Black	1
<b>BAG#1406</b>			
B	49-490310-000	Flat Washer, M8 SAE, Black	4
C	34-345607-000	Compression Limiter, Zinc, Black	4
D	50-571028-000	Hex Bolt, Flange, M8X25, Zinc, Black	2
E	50-571029-000	Hex Bolt, Flange, M8X30, Zinc, Black	2

### TOOLS REQUIRED FOR ASSEMBLY

Ratchet Wrench	5mm Allen Wrench
13mm Socket	4mm Allen Wrench
12mm Socket	

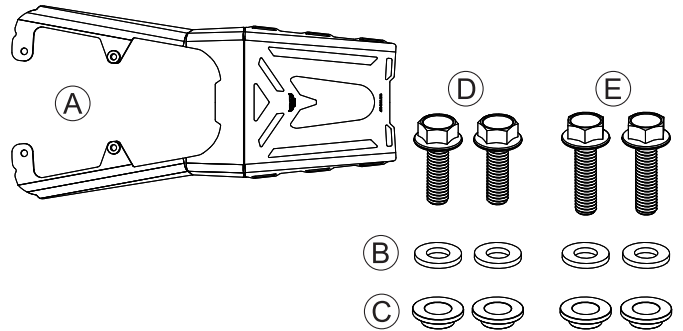

**ATTENTION:** Special notes and cautionary measures which can prevent damage to the accessory or vehicle.



**NOTE:** Tips for facilitation of operation, control and adjustment, as well as maintenance work.



**Step 01**



**Step 02**

### PREPARATION

Place your motorcycle securely on its sidestand to begin working. You'll begin by removing the front and rear seats.

#### Step 01

To remove the rear seat, turn the ignition key counter-clockwise until you hear the rear seat pop loose, then remove the rear seat.

#### Step 02

Use a 5mm Allen Wrench to remove the two bolts securing the front seat, and then remove the seat.

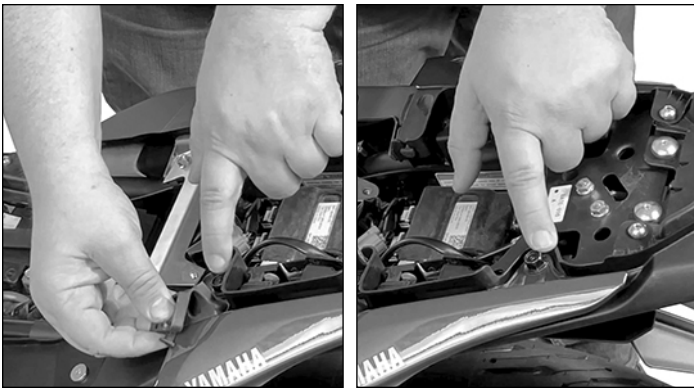

Step 03

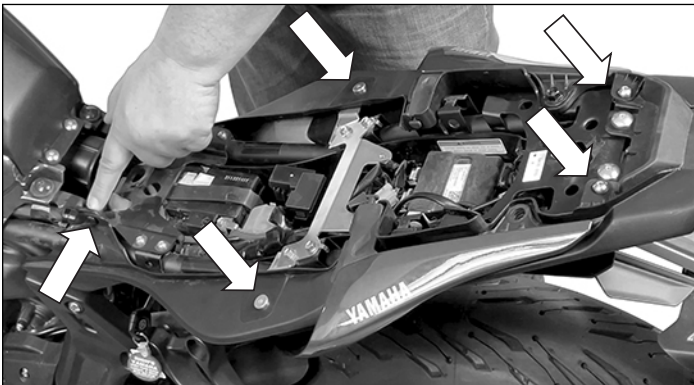

Step 04

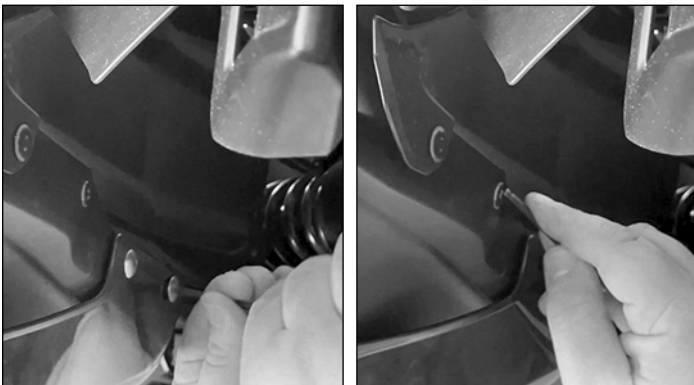

Step 05



Step 06

**INSTALLATION**

**Step 03**

Start by removing the bike's body panel sections. Lift up the rubber covers as shown to expose the 12mm bolts underneath. Use your Ratchet Wrench and 12mm Socket to remove these bolts.

Next, remove the two bolts at the back of the outer bodycolor panels with your 12mm Socket.

These four bolts and their compression collars will not be reused.

**Step 04**

The inner black side panel sections are secured by three pairs of screws (indicated). Use a 4mm Allen Wrench to remove these screws. Set them aside for later reinstallation.

**Step 05**

Move to the underside of the bike's two side panel sections. You will see two screws securing each of the two outer bodycolor sections. Remove the screws with a 4mm Allen Wrench and set them aside for later reinstallation.

The inner black body panel sections are secured underneath by a small body pin (front) and a large body pin (rear). Use the pointed end of your 4mm Allen Wrench to push the button in the middle of the pins until they pop. The pins can then be removed.

**Step 06-07**

The inner black body panel and outer bodycolor panel assemblies can now be removed from the bike. The assemblies are secured by two tapered pins that go into grommeted receptacles.

Carefully pull out the front of the assembly until it is loose. Do the same at the rear of the assembly.



Step 07

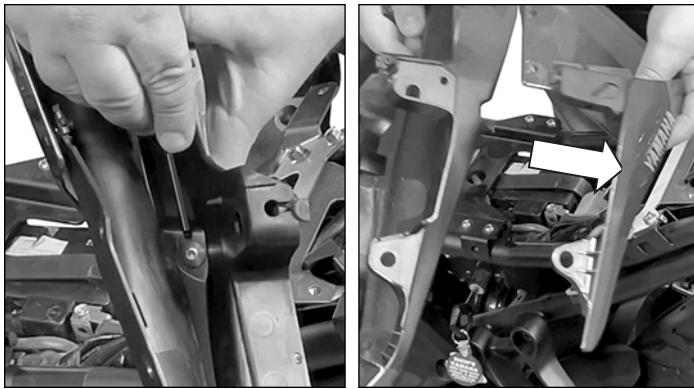

Step 08



Step 09

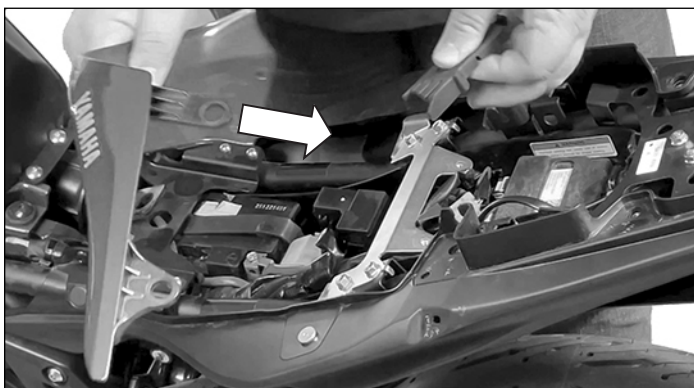

Step 10

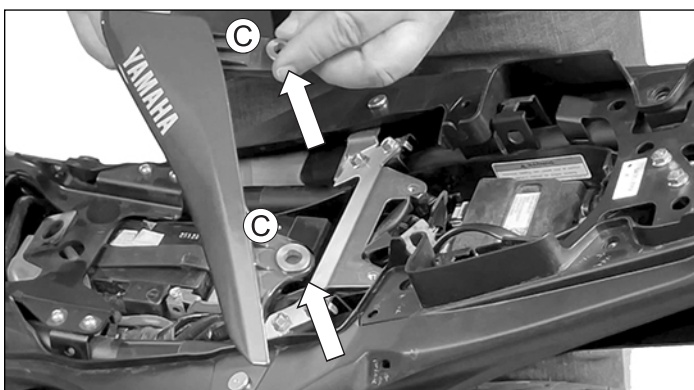

Step 11

## INSTALLATION; CONT'D

### Step 08

Each inner black side panel and outer bodycolor panel are joined inside by a screw. Use your 4mm Allen Wrench to remove this screw, separating these two pieces. This screw will not be reused.

### Step 09

Now you will reinstall the inner black body panels without the bodycolor panels. Push the front tapered pin into the grommated receptacle until you feel it pop into place. Do the same at the rear of the panel.

Next, reinstall the three pairs of screws that were removed earlier in Step 04. They should be installed just finger-tight for now.

### Step 10

Return the outer bodycolor panels in place. Begin by removing the large rubber cover from each panel and set them aside.

### Step 11

Install the Luggage Rack Kit's Compression Limiters (C) into the top of the mount holes in the bodycolor panels. Put the outer bodycolor panels aside, but leave them within easy reach.

### Step 12

Set the Luggage Rack (A) in place.

 **NOTE:** It helps to have a second pair of hands for this procedure.

Line up the Luggage Rack on the bike with the mount holes over the four points where the 12mm bolts were removed earlier.

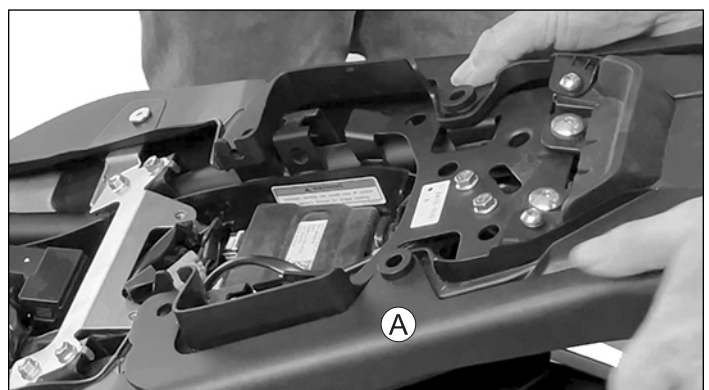

Step 12

## INSTALLATION; CONT'D

### Step 13

Now place the outer bodycolor panels with their new Compression Limiters **(C)** into place over the mount holes.

### Step 14

Secure the inner black body panel, Luggage Rack, and outer bodycolor panels with the Bolts and Flat Washers **(B)** provided in the Kit.

The 30mm Hex Bolts **(E)** and Flat Washers go into the rear of the Luggage Rack while the shorter 25MM Hex Bolts **(D)** and Flat Washers go into the front of the Luggage Rack.

### Step 15

Leave these four Hex Bolts **(D,E)** just finger-tight for right now.

### Step 16

Move back to the underside of the bike's two body panel sections with the screws and body pins you removed earlier. Take the body pins and push the pointed ends in until it makes a protruded button on the cap.

### Step 17

Reinsert the body pins into their original location (smaller pins towards the front, larger pin towards the rear). With the caps fully seated against the inner black body panel, push the buttons until you hear them click.

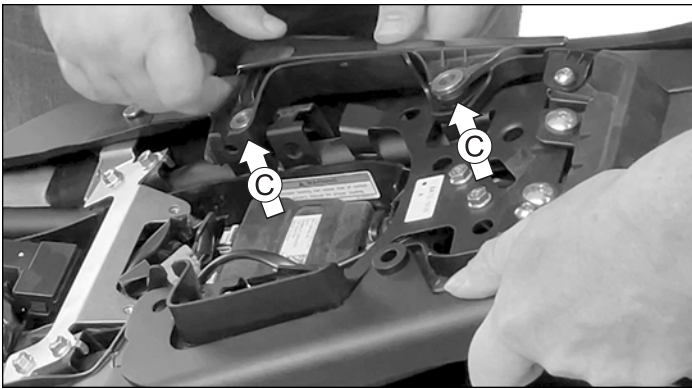

Step 13

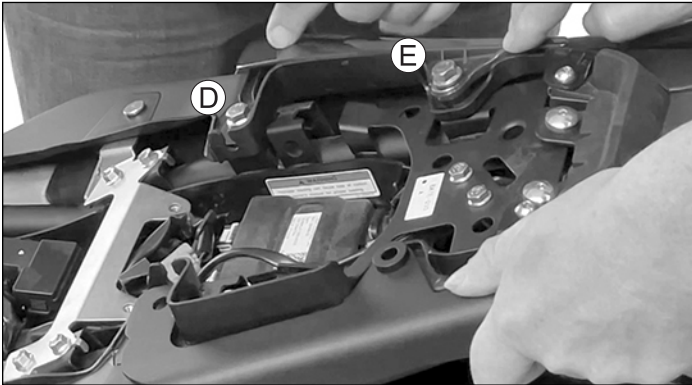

Step 14

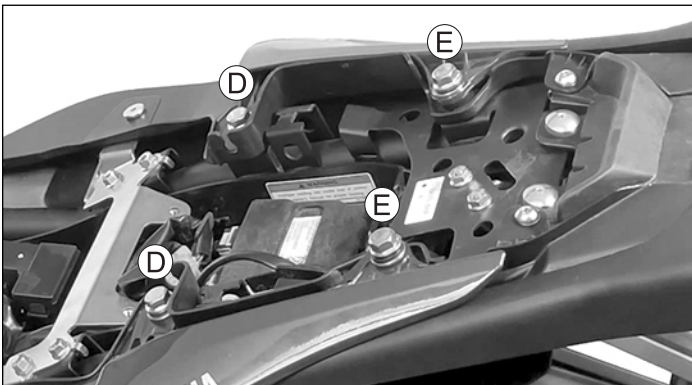

Step 15

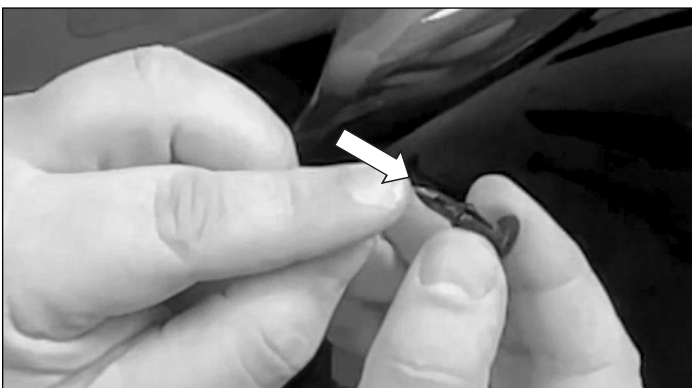

Step 16



Step 17



Step 18

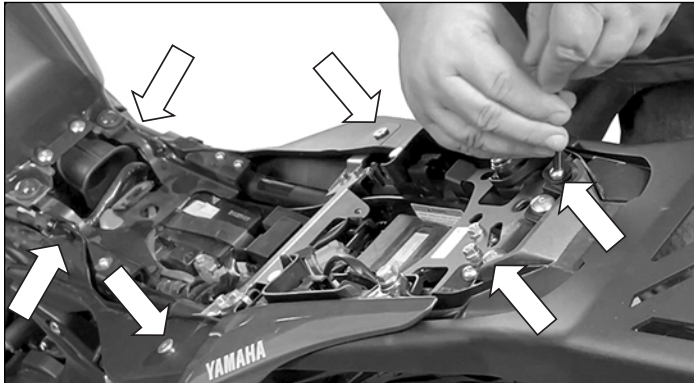

Step 19



Step 20

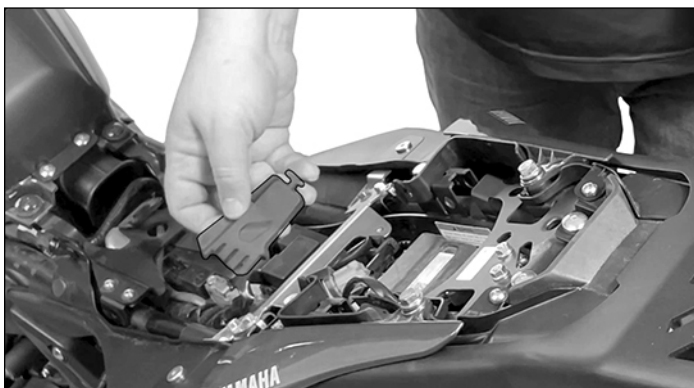

Step 21

## INSTALLATION; CONT'D

### Step 18

Now reinstall the four screws removed in Step 06 with a 4mm Allen Wrench. Tighten them securely.

### Step 19

Move back up to the top of the bike and use a 4 mm Allen Wrench to securely tighten the three pairs of screws that attach the inner black body panels to the bike.

### Step 20

Use a Ratchet Wrench and a 13mm Socket to securely tighten the four main bolts (D,E) that attach the Luggage Rack and outer bodycolor panels to the bike.

### Step 21

Reinstall the rubber covers that were removed in Step 12. Slide them into their original position with their T-hooks engaged.



**NOTE:** Before reinstalling the seats, double-check all fasteners for tightness.

### Step 22

Reinstall the front seat with its two mounting bolts and tighten them securely with a 5mm Allen Wrench.



Step 22



**Step 23**

## INSTALLATION; CONT'D

### Step 23

Lastly, put the rear seat into position and press down on the rear half until you hear it lock into place.

### Step 24

Your installation is now complete.

**Ride safe and enjoy your new National Cycle Luggage Rack!**



**Step 24**

## **WARNING**

Never operate your vehicle with loose accessory mounting hardware. Check the hardware for tightness regularly.

Motorcycles are built with enough frame rigidity to withstand the moderate loads imposed on them by the foreseeable addition of an accessory(ies). If an accessory(ies) adversely affects your vehicle's stability, immediately remove the accessory(ies). Do not operate a vehicle that exhibits unsafe handling traits.

Have experienced service personnel correct any problem before driving with the accessory(ies) installed. For further questions concerning handling problems associated with an accessory(ies), contact your dealer, motorcycle manufacturer, or accessory manufacturer.

