



Scan QR Code to Watch
Our Installation Video

Quantum® Hardcoated Polycarbonate
VStream+® Windscreen for:
2023-Current BMW® R1250R

Z2363 Low; Dark Tint
Z2364 Mid; Light Tint
Z2365 Tall; Clear



VStream® Windscreen Patent No. 7,387,328

Thank you for purchasing a ZTechnik product. Read these instructions carefully and thoroughly before beginning work. Dealers, if installing this windscreen for a customer, please give them this manual upon completion. It contains information needed to properly maintain and use this product.

Description:	VStream+® Windscreen/Mount Kit	Model:	2023-Current BMW® R1250R
Part Number:	Z2363/Z2364/Z2365	Installation Time:	45 min. Difficulty Level: Moderate

PACKAGE CONTENTS

Index	Part Number	Item Description	Qty.
A		ZTechnik VStream+ Windscreen	1
B	44-447308-000	Rubber Grommet, Pre-Installed	4
C	37-370285-000	Windscreen Bracket Mount; Right	1
D	37-370287-000	Bracket Clamp; Right	1
E	37-370284-000	Windscreen Bracket Mount; Left	1
F	37-370286-000	Bracket Clamp; Left	1
BAG1435			
G	51-515317-000	Stainless Hex Cap Screw, M6-1.0x16	4
H	49-490511-000	Stainless Flat Washer, M6	4
I	34-346037-000	Aluminum Cap, Black Anodized	4
J	51-514212-000	Stainless Flathead Screw, Hex, M6x12	4
K	75-764052-000	Rubber Clamp Spacers, Black	4
L	44-448730-000	Wire Ties, Black	2

TOOLS REQUIRED

T-25 Torx Wrench or T-Handle	Small Wire Cutters
T-27 Torx Wrench or T-Handle	Small Flathead Screwdriver
5mm Allen Wrench	4mm Allen Wrench

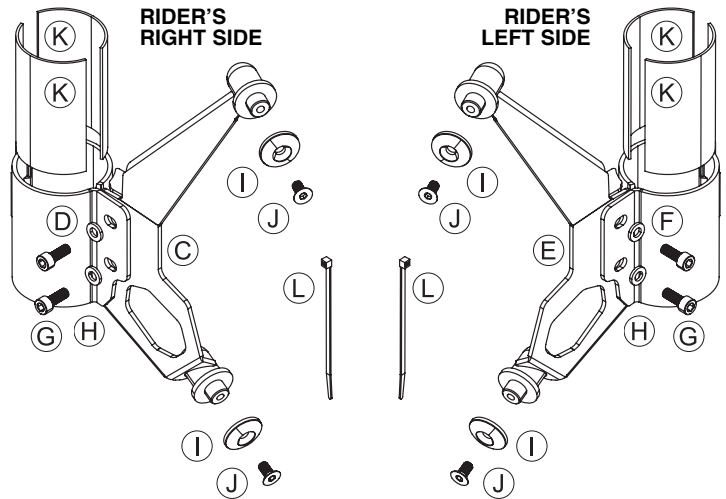

ATTENTION: Special notes and cautionary measures which can prevent damage to the accessory or vehicle.



NOTE: Tips for facilitation of operation, control and adjustment, as well as maintenance work.



Step 01

PREPARATION

Place motorcycle securely on its centerstand.

Check all the Windscreen Mounting Kit's parts and make sure you have everything at hand and sorted out.

Make sure you have the required tools available.

Step 01

With a T-25 Torx Wrench, loosen and remove the two screws from the front cover panel of the speedometer housing. Save these screws for later reinstallation.



Step 02

PREPARATION; CONT'D.

Step 02

Pull front cover panel straight out to remove it.

Step 03

Disconnect the wire harness from the back of speedometer display by pressing on both sides of the harness coupling.

Step 04

Remove the three "e" clips that hold the speedometer display in place. Save these clips for later reinstallation.

Step 05

Remove the entire speedometer display from its bracket and carefully set it aside.

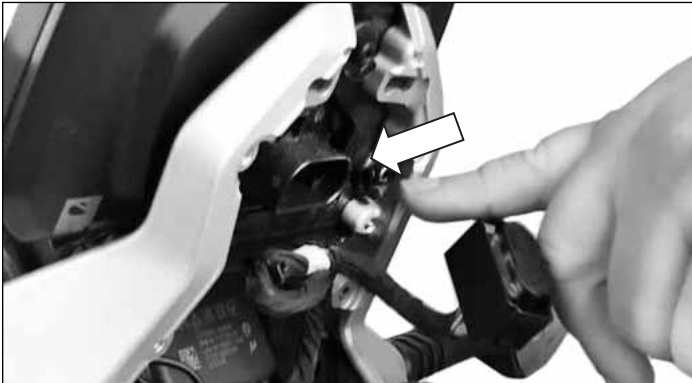

Step 03

Step 06

With a pair of Small Wire Cutters, carefully cut the cable ties holding the left/right turn signal wires to the "tree" plugs embedded into the body. Leave these plugs in place. New cable ties will be threaded through them in **Step 15**.

Step 07

Insert a Small Flathead Screwdriver into the turn signal wire coupling to disconnect the turn signals from the main wire harness.



Step 04



Step 05

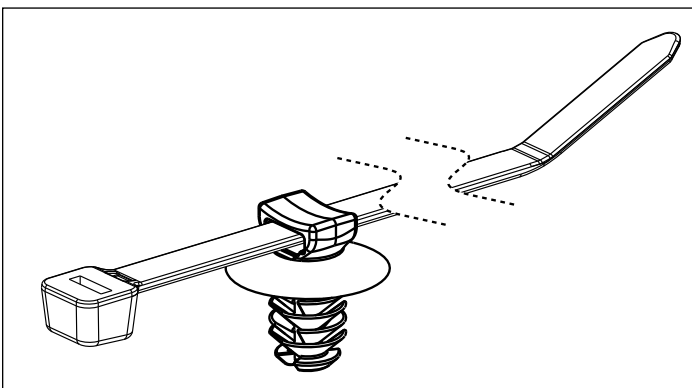

Step 06



Step 07



Step 08

PREPARATION; CONT'D.

Step 08

Use a T-27 Torx Wrench to unbolt the left and right turn signals. Save these screws for later reinstallation.

Step 09

Rotate each turn signal 180° and then pull them straight out from their mount points. Carefully set them aside.



Step 09

MOUNTING KIT INSTALLATION

Step 10

Apply the adhesive Rubber Clamp Spacers (**K**) to the inside surface of both Windscreen Bracket Mounts (**C/E**) and Bracket Clamps (**D/F**).

Step 11

Starting on the right side of the bike, place the inner Windscreen Bracket Mount; Right (**C**) low on the fork tubes and pointing out to the side of the bike.

Step 12

Lift the Windscreen Bracket Mount to the top of the fork tubes and up against the top triple clamp. Rotate the Bracket Mount so that the mount arms face forward.



Step 10



Step 11



Step 12

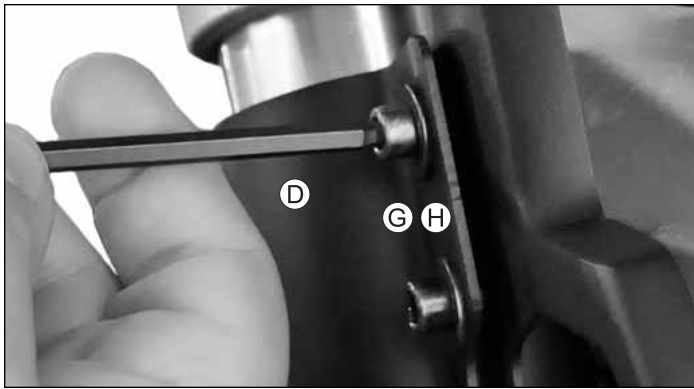

Step 13

MOUNTING KIT INSTALLATION; CONT'D.

Step 13

Install the outer Bracket Clamp; Right (D), making sure the slot in the back hooks to the tab on the Windscreen Bracket Mount. Fold the outer Bracket Clamp against the fork tubes and secure with two Stainless Hex Socket Cap Screws (G) and two Flat Washers (H).

Tighten slightly with a 5mm Allen Wrench, but leave the assembly loose enough so that it can be rotated into its final position.

Step 14

Reinstall the turn signal and its wiring through the cutout in the Windscreen Bracket Mount. Orient the turn signal 180° from its original position and rotate until it seats. Secure the turn signal with its original mounting bolt.



Step 14

Step 15

Plug the turn signal wiring back into the wiring harness coupling. Thread a new Wire Tie (L) into the original "tree" plug (see illustration inset), lay the turn signal wiring inside the Wire Tie, and tighten it.

 Repeat **Steps 11-15** on the left side of the motorcycle.

Step 16

Reinstall the speedometer display with the original "E" clips and reconnect the wire harness.

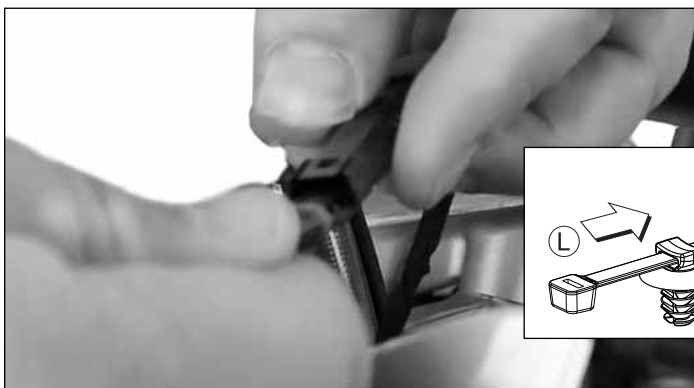

Step 15

Step 17

Reinstall the front cover panel and secure with the original bolts.



Step 16



Step 17

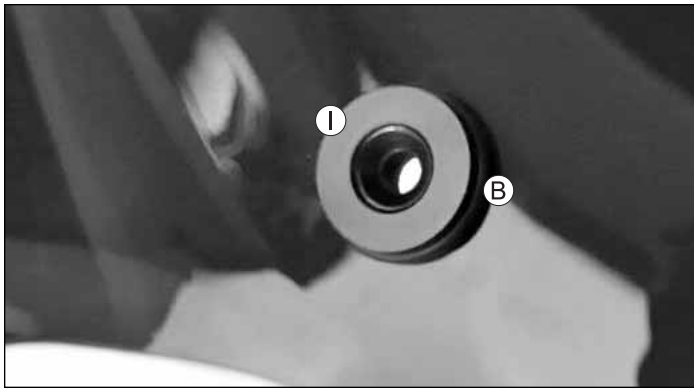

Step 18



Step 19



Step 20

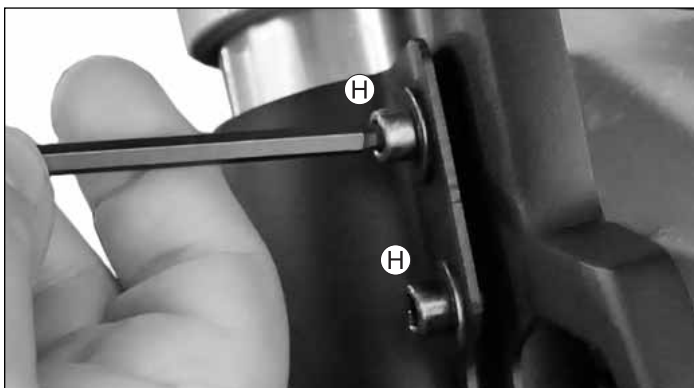

Step 21

WINDSCREEN INSTALLATION

Step 18

The four Rubber Grommets (B) are pre-installed into the Windscreen. Position the Windscreen to the mounting points of the left and right Windscreen Bracket Mounts/Bracket Clamps.

Install the four Aluminum Caps (I) into the Rubber Grommets in the Windscreen as shown, and place the Windscreen into position on the Left/Right Bracket Mounts.

Since the Mounts/Clamps are slightly loose, the hardware can be rotated on the fork tubes for a symmetrical forward-facing Windscreen position.

Step 19-20

Attach the Windscreen to the mount points on the Windscreen Brackets and secure with four Stainless Flat Head Screws (J). Tighten with a 4mm Allen Wrench

Step 21

Double-check everything for proper alignment, spacing and tightness. Then securely tighten the Stainless Hex Socket Cap Screws (H) on both left and right sides with a 5mm Allen Wrench.

Ride safe and enjoy the performance benefits of your new VStream+® Windscreen!





CLEANING AND MAINTENANCE

To clean the screen, wash with a clean soft cloth and plenty of warm water and, if necessary, a non-abrasive soap such as dishwashing liquid. Flannel or soft chamois make good cleaning cloths. Paint, glue residue or grease removal: Moisten cotton wad with naphtha or turpentine followed by a wash as above.

National Cycle **Shield Wash™** (N1401-01) makes a good daily cleaner and comes with a handy travel-size bottle. Shield Wash is safe for all windshields and helmet visors

Do not clean polycarbonate in hot sun or high temperatures. Do not clean the screen with household glass cleaners. Do not allow brake fluid, alcohol, or strong solvents to contact the screen.

RAIN REPELLENT

Do not use rain protective products made for glass. We recommend National Cycle's **RainZip®** (N1410-01) to keep your windshield clear in rainy weather.



Register Your Windshield Online at www.nationalcycle.com

National Cycle/ZTechnik 3-Year Limited Warranty

National Cycle hereby warrants to the original registered owner of a National Cycle polycarbonate windshield for a period of three years from the date of purchase against breakage. This limited warranty is expressly limited to the replacement of the polycarbonate windshield. This limited warranty does not include scratches, coating failure, cosmetic wear and tear, replacement of hardware, or any consequential damages or expenses including labor cost of installation, removal and/or replacement, inconvenience, inbound freight expenses or damage to any other component of the motorcycle or any other accessories. Certain chemicals, generally known as acidic hydrocarbons, are known to cause polycarbonate damage and will not be covered under this limited warranty. Please refer to the cleaning instructions supplied with all National Cycle windshields.

Visit www.nationalcycle.com for further details, or call or write National Cycle

⚠ WARNING

Never ride your motorcycle with loose accessory mounting hardware. Check the hardware for tightness regularly.

Today's motorcycles are built with enough frame rigidity to withstand the moderate loads imposed on them by the foreseeable addition of an accessory(ies). If an accessory(ies) adversely affects your motorcycle's stability, immediately remove the accessory(ies). Do not ride a motorcycle that exhibits unsafe handling traits.

Have experienced service personnel correct any problem before riding with the accessory(ies) installed. For further questions concerning handling problems associated with an accessory(ies), contact your dealer, motorcycle manufacturer, or accessory manufacturer.

Sunlight reflected off the inside curvature of the windshield can, at certain times of day, cause extreme heat buildup on the motorcycles instruments and possibly even melt them. Exercise care in parking to avoid this. Park your motorcycle facing the sun or place an opaque object over this area.

